



**COMMONWEALTH OF PENNSYLVANIA
DEPARTMENT OF ENVIRONMENTAL PROTECTION
AIR QUALITY PROGRAM**

STATE ONLY SYNTHETIC MINOR OPERATING PERMIT

Issue Date: March 27, 2025

Effective Date: April 1, 2025

Expiration Date: March 31, 2030

In accordance with the provisions of the Air Pollution Control Act, the Act of January 8, 1960, P.L. 2119, as amended, and 25 Pa. Code Chapter 127, the Owner, [and Operator if noted] (hereinafter referred to as permittee) identified below is authorized by the Department of Environmental Protection (Department) to operate the air emission source(s) more fully described in this permit. This Facility is subject to all terms and conditions specified in this permit. Nothing in this permit relieves the permittee from its obligations to comply with all applicable Federal, State and Local laws and regulations.

The regulatory or statutory authority for each permit condition is set forth in brackets. All terms and conditions in this permit are federally enforceable unless otherwise designated.

State Only Permit No: 21-05035

Synthetic Minor

Federal Tax Id - Plant Code: 23-1374051-48

Owner Information

Name: NEW ENTERPRISE STONE & LIME CO INC

Mailing Address: 3912 BRUMBAUGH RD
NEW ENTERPRISE, PA 16664-9137

Plant Information

Plant: NESL/LOCUST POINT QUARRY

Location: 21 Cumberland County 21925 Silver Spring Township

SIC Code: 1422 Mining - Crushed And Broken Limestone

Responsible Official

Name: MICHAEL A CLARK

Title: VP-PRODUCTION SERVICES

Phone: (814) 766 - 2211

Email: mclark@nesl.com

Permit Contact Person

Name: GREG WILLI

Title: GEO-ENV SPECIALIST

Phone: (717) 504 - 6286

Email: Gwilli@nesl.com

[Signature] _____

WILLIAM R. WEAVER, SOUTH CENTRAL REGION AIR PROGRAM MANAGER

**SECTION A. Table of Contents****Section A. Facility/Source Identification**

Table of Contents
Site Inventory List

Section B. General State Only Requirements

- #001 Definitions.
- #002 Operating Permit Duration.
- #003 Permit Renewal.
- #004 Operating Permit Fees under Subchapter I.
- #005 Transfer of Operating Permits.
- #006 Inspection and Entry.
- #007 Compliance Requirements.
- #008 Need to Halt or Reduce Activity Not a Defense.
- #009 Duty to Provide Information.
- #010 Revising an Operating Permit for Cause.
- #011 Operating Permit Modifications
- #012 Severability Clause.
- #013 De Minimis Emission Increases.
- #014 Operational Flexibility.
- #015 Reactivation of Sources
- #016 Health Risk-based Emission Standards and Operating Practice Requirements.
- #017 Circumvention.
- #018 Reporting Requirements.
- #019 Sampling, Testing and Monitoring Procedures.
- #020 Recordkeeping.
- #021 Property Rights.
- #022 Alternative Operating Scenarios.
- #023 Reporting
- #024 Report Format

Section C. Site Level State Only Requirements

- C-I: Restrictions
- C-II: Testing Requirements
- C-III: Monitoring Requirements
- C-IV: Recordkeeping Requirements
- C-V: Reporting Requirements
- C-VI: Work Practice Standards
- C-VII: Additional Requirements
- C-VIII: Compliance Certification
- C-IX: Compliance Schedule

Section D. Source Level State Only Requirements

- D-I: Restrictions
- D-II: Testing Requirements
- D-III: Monitoring Requirements
- D-IV: Recordkeeping Requirements
- D-V: Reporting Requirements
- D-VI: Work Practice Standards
- D-VII: Additional Requirements

Note: These same sub-sections are repeated for each source!

Section E. Source Group Restrictions

- E-I: Restrictions



SECTION A. Table of Contents

- E-II: Testing Requirements
- E-III: Monitoring Requirements
- E-IV: Recordkeeping Requirements
- E-V: Reporting Requirements
- E-VI: Work Practice Standards
- E-VII: Additional Requirements

Section F. Alternative Operating Scenario(s)

- F-I: Restrictions
- F-II: Testing Requirements
- F-III: Monitoring Requirements
- F-IV: Recordkeeping Requirements
- F-V: Reporting Requirements
- F-VI: Work Practice Standards
- F-VII: Additional Requirements

Section G. Emission Restriction Summary

Section H. Miscellaneous

**SECTION A. Site Inventory List**

Source ID	Source Name	Capacity/Throughput	Fuel/Material
101	LIMESTONE CRUSHING PLANT	500.000 Tons/HR	LIMESTONE
104	BATCH CONCRETE PLANT	200.000 Cu Yd/HR	CONCRETE
201	BATCH ASPHALT PLANT	95.000 MMBTU/HR	
		405.000 Tons/HR	ASPHALT
		95.000 MCF/HR	Natural Gas
C101	WET SUPPRESSION SYSTEM		
C104A	CEMENT SILO #1 - BIN VENT COLLECTOR		
C104B	CEMENT SILO #2 - BIN VENT COLLECTOR		
C104C	CEMENT SILO #3 - BIN VENT COLLECTOR		
C104D	WEIGH HOPPER - BIN VENT COLLECTOR		
C104E	FLY ASH SILO - BIN VENT COLLECTOR		
C201A	KNOCKOUT BOX		
C201B	FABRIC COLLECTOR		
FML25	NATURAL GAS PIPELINE		
S201	SOURCE 201 STACK		
Z101	SOURCE 101 FUGITIVE EMISSIONS		
Z104A	CEMENT SILO #1 BIN VENT FUGITIVE EMISSIONS		
Z104B	CEMENT SILO #2 BIN VENT FUGITIVE EMISSIONS		
Z104C	CEMENT SILO #3 BIN VENT FUGITIVE EMISSIONS		
Z104D	WEIGH HOPPER BIN VENT FUGITIVE EMISSIONS		
Z104E	FLY ASH SILO BIN VENT FUGITIVE EMISSIONS		
Z201	BATCH ASPHALT PLANT FUGITIVE EMISSIONS		

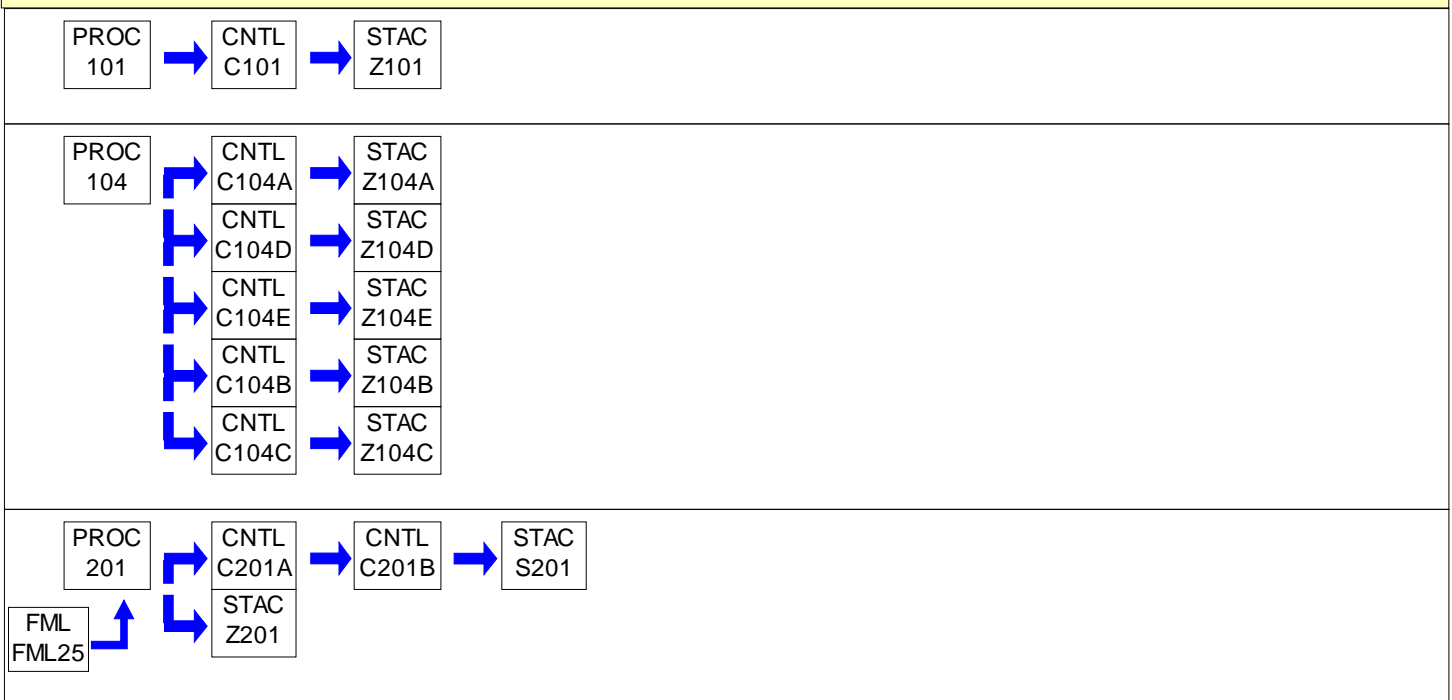
PERMIT MAPS

**SECTION B. General State Only Requirements****#001 [25 Pa. Code § 121.1]****Definitions.**

Words and terms that are not otherwise defined in this permit shall have the meanings set forth in Section 3 of the Air Pollution Control Act (35 P.S. § 4003) and in 25 Pa. Code § 121.1.

#002 [25 Pa. Code § 127.446]**Operating Permit Duration.**

- (a) This operating permit is issued for a fixed term of five (5) years and shall expire on the date specified on Page 1 of this permit.
- (b) The terms and conditions of the expired permit shall automatically continue pending issuance of a new operating permit, provided the permittee has submitted a timely and complete application and paid applicable fees required under 25 Pa. Code Chapter 127, Subchapter I and the Department is unable, through no fault of the permittee, to issue or deny a new permit before the expiration of the previous permit.

#003 [25 Pa. Code §§ 127.412, 127.413, 127.414, 127.446 & 127.703(b)]**Permit Renewal.**

- (a) The permittee shall submit a timely and complete application for renewal of the operating permit to the appropriate Regional Air Program Manager. The application for renewal of the operating permit shall be submitted at least six (6) months and not more than 18 months before the expiration date of this permit.
- (b) The application for permit renewal shall include the current permit number, a description of any permit revisions that occurred during the permit term, and any applicable requirements that were promulgated and not incorporated into the permit during the permit term. An application is complete if it contains sufficient information to begin processing the application, has the applicable sections completed and has been signed by a responsible official.
- (c) The permittee shall submit with the renewal application a fee for the processing of the application as specified in 25 Pa. Code § 127.703(b). The fees shall be made payable to "The Commonwealth of Pennsylvania Clean Air Fund" and submitted with the fee form to the respective regional office.
- (d) The renewal application shall also include submission of proof that the local municipality and county, in which the facility is located, have been notified in accordance with 25 Pa. Code § 127.413.
- (e) The application for renewal of the operating permit shall also include submission of supplemental compliance review forms in accordance with the requirements of 25 Pa. Code § 127.412(b) and § 127.412(j).
- (f) The permittee, upon becoming aware that any relevant facts were omitted or incorrect information was submitted in the permit application, shall promptly submit such supplementary facts or corrected information as necessary to address any requirements that become applicable to the source after the permittee submits a complete application, but prior to the date the Department takes action on the permit application.

#004 [25 Pa. Code § 127.703]**Operating Permit Fees under Subchapter I.**

- (a) The permittee shall pay the annual operating permit maintenance fee according to the following fee schedule in either paragraph (1) or (2) in accordance with 25 Pa. Code § 127.703(d) on or before December 31 of each year for the next calendar year.
- (1) For a synthetic minor facility, a fee equal to:
- (i) Four thousand dollars (\$4,000) for calendar years 2021—2025.
 - (ii) Five thousand dollars (\$5,000) for calendar years 2026—2030.
 - (iii) Six thousand three hundred dollars (\$6,300) for the calendar years beginning with 2031.

**SECTION B. General State Only Requirements**

(2) For a facility that is not a synthetic minor, a fee equal to:

- (i) Two thousand dollars (\$2,000) for calendar years 2021—2025.
- (ii) Two thousand five hundred dollars (\$2,500) for calendar years 2026—2030.
- (iii) Three thousand one hundred dollars (\$3,100) for the calendar years beginning with 2031.

(b) The applicable fees shall be made payable to "The Commonwealth of Pennsylvania Clean Air Fund" with the permit number clearly indicated and submitted to the respective regional office.

#005 [25 Pa. Code §§ 127.450 (a)(4) and 127.464]**Transfer of Operating Permits.**

(a) This operating permit may not be transferred to another person, except in cases of transfer-of-ownership that are documented and approved by the Department.

(b) In accordance with 25 Pa. Code § 127.450(a)(4), a change in ownership of the source shall be treated as an administrative amendment if the Department determines that no other change in the permit is required and a written agreement has been submitted to the Department identifying the specific date of the transfer of permit responsibility, coverage and liability between the current and the new permittee and a compliance review form has been submitted to, and the permit transfer has been approved by, the Department.

(c) This operating permit is valid only for those specific sources and the specific source locations described in this permit.

#006 [25 Pa. Code § 127.441 and 35 P.S. § 4008]**Inspection and Entry.**

(a) Upon presentation of credentials and other documents as may be required by law, the permittee shall allow the Department or authorized representatives of the Department to perform the following:

(1) Enter at reasonable times upon the permittee's premises where a source is located or emissions related activity is conducted, or where records are kept under the conditions of this permit;

(2) Have access to and copy, at reasonable times, any records that are kept under the conditions of this permit;

(3) Inspect at reasonable times, any facilities, equipment including monitoring and air pollution control equipment, practices, or operations regulated or required under this permit;

(4) Sample or monitor, at reasonable times, any substances or parameters, for the purpose of assuring compliance with the permit or applicable requirements as authorized by the Clean Air Act, the Air Pollution Control Act, or the regulations promulgated under the Acts.

(b) Pursuant to 35 P.S. § 4008, no person shall hinder, obstruct, prevent or interfere with the Department or its personnel in the performance of any duty authorized under the Air Pollution Control Act or regulations adopted thereunder including denying the Department access to a source at this facility. Refusal of entry or access may constitute grounds for permit revocation and assessment of criminal and/or civil penalties.

(c) Nothing in this permit condition shall limit the ability of the EPA to inspect or enter the premises of the permittee in accordance with Section 114 or other applicable provisions of the Clean Air Act.

#007 [25 Pa. Code §§ 127.441 & 127.444]**Compliance Requirements.**

(a) The permittee shall comply with the conditions of this operating permit. Noncompliance with this permit constitutes a violation of the Clean Air Act and the Air Pollution Control Act and is grounds for one or more of the following:

**SECTION B. General State Only Requirements**

- (1) Enforcement action
- (2) Permit termination, revocation and reissuance or modification
- (3) Denial of a permit renewal application

(b) A person may not cause or permit the operation of a source which is subject to 25 Pa. Code Article III unless the source(s) and air cleaning devices identified in the application for the plan approval and operating permit and the plan approval issued for the source is operated and maintained in accordance with specifications in the applications and the conditions in the plan approval and operating permit issued by the Department. A person may not cause or permit the operation of an air contamination source subject to 25 Pa. Code Chapter 127 in a manner inconsistent with good operating practices.

(c) For purposes of Sub-condition (b) of this permit condition, the specifications in applications for plan approvals and operating permits are the physical configurations and engineering design details which the Department determines are essential for the permittee's compliance with the applicable requirements in this State-Only permit. Nothing in this sub-condition shall be construed to create an independent affirmative duty upon the permittee to obtain a predetermination from the Department for physical configuration or engineering design detail changes made by the permittee.

#008 [25 Pa. Code § 127.441]**Need to Halt or Reduce Activity Not a Defense.**

It shall not be a defense for the permittee in an enforcement action that it was necessary to halt or reduce the permitted activity in order to maintain compliance with the conditions of this permit.

#009 [25 Pa. Code §§ 127.442(a) & 127.461]**Duty to Provide Information.**

(a) The permittee shall submit reports to the Department containing information the Department may prescribe relative to the operation and maintenance of each source at the facility.

(b) The permittee shall furnish to the Department, in writing, information that the Department may request to determine whether cause exists for modifying, revoking and reissuing, or terminating this permit, or to determine compliance with the permit. Upon request, the permittee shall also furnish to the Department copies of records that the permittee is required to maintain in accordance with this permit.

#010 [25 Pa. Code § 127.461]**Revising an Operating Permit for Cause.**

This operating permit may be terminated, modified, suspended or revoked and reissued if one or more of the following applies:

- (1) The permittee constructs or operates the source subject to the operating permit so that it is in violation of the Air Pollution Control Act, the Clean Air Act, the regulations thereunder, a plan approval, a permit or in a manner that causes air pollution.
- (2) The permittee fails to properly or adequately maintain or repair an air pollution control device or equipment attached to or otherwise made a part of the source.
- (3) The permittee has failed to submit a report required by the operating permit or an applicable regulation.
- (4) The EPA determines that the permit is not in compliance with the Clean Air Act or the regulations thereunder.

#011 [25 Pa. Code §§ 127.450, 127.462, 127.465 & 127.703]**Operating Permit Modifications**

(a) The permittee is authorized to make administrative amendments, minor operating permit modifications and significant operating permit modifications, under this permit, as outlined below:

**SECTION B. General State Only Requirements**

(b) Administrative Amendments. The permittee shall submit the application for administrative operating permit amendments (as defined in 25 Pa. Code § 127.450(a)), according to procedures specified in § 127.450 unless precluded by the Clean Air Act or its regulations.

(c) Minor Operating Permit Modifications. The permittee shall submit the application for minor operating permit modifications (as defined 25 Pa. Code § 121.1) in accordance with 25 Pa. Code § 127.462.

(d) Significant Operating Permit Modifications. The permittee shall submit the application for significant operating permit modifications in accordance with 25 Pa. Code § 127.465.

(e) The applicable fees shall be made payable to "The Commonwealth of Pennsylvania Clean Air Fund" with the permit number clearly indicated and submitted to the respective regional office.

#012 [25 Pa. Code § 127.441]**Severability Clause.**

The provisions of this permit are severable, and if any provision of this permit is determined by a court of competent jurisdiction to be invalid or unenforceable, such a determination will not affect the remaining provisions of this permit.

#013 [25 Pa. Code § 127.449]**De Minimis Emission Increases.**

(a) This permit authorizes de minimis emission increases in accordance with 25 Pa. Code § 127.449 so long as the permittee provides the Department with seven (7) days prior written notice before commencing any de minimis emissions increase. The written notice shall:

(1) Identify and describe the pollutants that will be emitted as a result of the de minimis emissions increase.

(2) Provide emission rates expressed in tons per year and in terms necessary to establish compliance consistent with any applicable requirement.

(b) The Department may disapprove or condition de minimis emission increases at any time.

(c) Except as provided below in (d), the permittee is authorized to make de minimis emission increases (expressed in tons per year) up to the following amounts without the need for a plan approval or prior issuance of a permit modification:

(1) Four tons of carbon monoxide from a single source during the term of the permit and 20 tons of carbon monoxide at the facility during the term of the permit.

(2) One ton of NO_x from a single source during the term of the permit and 5 tons of NO_x at the facility during the term of the permit.

(3) One and six-tenths tons of the oxides of sulfur from a single source during the term of the permit and 8.0 tons of oxides of sulfur at the facility during the term of the permit.

(4) Six-tenths of a ton of PM₁₀ from a single source during the term of the permit and 3.0 tons of PM₁₀ at the facility during the term of the permit. This shall include emissions of a pollutant regulated under Section 112 of the Clean Air Act unless precluded by the Clean Air Act, the regulations thereunder or 25 Pa. Code Article III.

(5) One ton of VOCs from a single source during the term of the permit and 5.0 tons of VOCs at the facility during the term of the permit. This shall include emissions of a pollutant regulated under Section 112 of the Clean Air Act unless precluded by the Clean Air Act, the regulations thereunder or 25 Pa. Code Article III.

(6) Other sources and classes of sources determined to be of minor significance by the Department.

(d) In accordance with § 127.14, the permittee is authorized to install the following minor sources without the need for a plan approval or permit modification:

**SECTION B. General State Only Requirements**

(1) Air conditioning or ventilation systems not designed to remove pollutants generated or released from other sources.

(2) Combustion units rated at 2,500,000 or less Btu per hour of heat input.

(3) Combustion units with a rated capacity of less than 10,000,000 Btu per hour heat input fueled by natural gas supplied by a public utility or by commercial fuel oils which are No. 2 or lighter, viscosity less than or equal to 5.82 c St, and which meet the sulfur content requirements of 25 Pa. Code §123.22 (relating to combustion units). For purposes of this permit, commercial fuel oil shall be virgin oil which has no reprocessed, recycled or waste material added.

(4) Space heaters which heat by direct heat transfer.

(5) Laboratory equipment used exclusively for chemical or physical analysis.

(6) Other sources and classes of sources determined to be of minor significance by the Department.

(e) This permit does not authorize de minimis emission increases if the emissions increase would cause one or more of the following:

(1) Increase the emissions of a pollutant regulated under Section 112 of the Clean Air Act except as authorized in Subparagraphs (c)(4) and (5) of this permit condition.

(2) Subject the facility to the prevention of significant deterioration requirements in 25 Pa. Code Chapter 127, Subchapter D and/or the new source review requirements in Subchapter E.

(3) Violate any applicable requirement of this permit, the Air Pollution Control Act, the Clean Air Act, or the regulations promulgated under either of the acts.

(f) Emissions authorized under this permit condition shall be included in the monitoring, recordkeeping and reporting requirements of this permit.

(g) Except for de minimis emission increases, installation of minor sources made pursuant to this permit condition and Plan Approval Exemptions under 25 Pa. Code § 127.14 (relating to exemptions), the permittee is prohibited from making changes or engaging in activities that are not specifically authorized under this permit without first applying for a plan approval. In accordance with § 127.14(b), a plan approval is not required for the construction, modification, reactivation, or installation of the sources creating the de minimis emissions increase.

(h) The permittee may not meet de minimis emission threshold levels by offsetting emission increases or decreases at the same source.

#014 [25 Pa. Code § 127.3]**Operational Flexibility.**

The permittee is authorized to make changes within the facility in accordance with the regulatory provisions outlined in 25 Pa. Code § 127.3 (relating to operational flexibility) to implement the operational flexibility requirements provisions authorized under Section 6.1(i) of the Air Pollution Control Act and the operational flexibility terms and conditions of this permit. The provisions in 25 Pa. Code Chapter 127 which implement the operational flexibility requirements include the following:

(1) Section 127.14 (relating to exemptions)

(2) Section 127.447 (relating to alternative operating scenarios)

(3) Section 127.448 (relating to emissions trading at facilities with Federally enforceable emissions caps)

(4) Section 127.449 (relating to de minimis emission increases)

(5) Section 127.450 (relating to administrative operating permit amendments)

**SECTION B. General State Only Requirements**

(6) Section 127.462 (relating to minor operating permit modifications)

(7) Subchapter H (relating to general plan approvals and general operating permits)

#015 [25 Pa. Code § 127.11a]**Reactivation of Sources**

(a) The permittee may not reactivate a source that has been out of operation or production for at least one year unless the reactivation is conducted in accordance with a plan approval granted by the Department or in accordance with reactivation and maintenance plans developed and approved by the Department in accordance with 25 Pa. Code § 127.11a(a).

(b) A source which has been out of operation or production for more than five (5) years but less than 10 years may be reactivated and will not be considered a new source if the permittee satisfies the conditions specified in 25 Pa. Code § 127.11a(b).

#016 [25 Pa. Code § 127.36]**Health Risk-based Emission Standards and Operating Practice Requirements.**

(a) When needed to protect public health, welfare and the environment from emissions of hazardous air pollutants from new and existing sources, the permittee shall comply with the health risk-based emission standards or operating practice requirements imposed by the Department, except as precluded by §§ 6.6(d)(2) and (3) of the Air Pollution Control Act [35 P.S. § 4006.6(d)(2) and (3)].

(b) A person challenging a performance or emission standard established by the Department has the burden to demonstrate that performance or emission standard does not meet the requirements of Section 112 of the Clean Air Act.

#017 [25 Pa. Code § 121.9]**Circumvention.**

No person may permit the use of a device, stack height which exceeds good engineering practice stack height, dispersion technique or other technique which, without resulting in reduction of the total amount of air contaminants emitted, conceals or dilutes an emission of air contaminants which would otherwise be in violation of 25 Pa. Code Article III, except that with prior approval of the Department, the device or technique may be used for control of malodors.

#018 [25 Pa. Code §§ 127.402(d) & 127.442]**Reporting Requirements.**

(a) The permittee shall comply with the applicable reporting requirements of the Clean Air Act, the regulations thereunder, the Air Pollution Control Act and 25 Pa. Code Article III including Chapters 127, 135 and 139.

(b) The permittee shall submit reports to the Department containing information the Department may prescribe relative to the operation and maintenance of any air contamination source.

(c) Reports, test data, monitoring data, notifications and requests for renewal of the permit shall be submitted to the:

Regional Air Program Manager
PA Department of Environmental Protection
(At the address given in the permit transmittal letter, or otherwise notified)

(d) Any records or information including applications, forms, or reports submitted pursuant to this permit condition shall contain a certification by a responsible official as to truth, accuracy and completeness. The certifications submitted under this permit shall require a responsible official of the facility to certify that based on information and belief formed after reasonable inquiry, the statements and information in the documents are true, accurate and complete.

(e) Any records, reports or information submitted to the Department shall be available to the public except for such

**SECTION B. General State Only Requirements**

records, reports or information which meet the confidentiality requirements of § 4013.2 of the Air Pollution Control Act and §§ 112(d) and 114(c) of the Clean Air Act. The permittee may not request a claim of confidentiality for any emissions data generated for the facility.

#019 [25 Pa. Code §§ 127.441(c) & 135.5]**Sampling, Testing and Monitoring Procedures.**

(a) The permittee shall comply with the monitoring, recordkeeping or reporting requirements of 25 Pa. Code Chapter 139 and the other applicable requirements of 25 Pa. Code Article III and additional requirements related to monitoring, reporting and recordkeeping required by the Clean Air Act and the regulations thereunder including the Compliance Assurance Monitoring requirements of 40 CFR Part 64, where applicable.

(b) Unless alternative methodology is required by the Clean Air Act and regulations adopted thereunder, sampling, testing and monitoring required by or used by the permittee to demonstrate compliance with any applicable regulation or permit condition shall be conducted in accordance with the requirements of 25 Pa. Code Chapter 139.

#020 [25 Pa. Code §§ 127.441(c) and 135.5]**Recordkeeping.**

(a) The permittee shall maintain and make available, upon request by the Department, the following records of monitored information:

- (1) The date, place (as defined in the permit) and time of sampling or measurements.
- (2) The dates the analyses were performed.
- (3) The company or entity that performed the analyses.
- (4) The analytical techniques or methods used.
- (5) The results of the analyses.
- (6) The operating conditions as existing at the time of sampling or measurement.

(b) The permittee shall retain records of any required monitoring data and supporting information for at least five (5) years from the date of the monitoring, sample, measurement, report or application. Supporting information includes the calibration data and maintenance records and original strip-chart recordings for continuous monitoring instrumentation, and copies of reports required by the permit.

(c) The permittee shall maintain and make available to the Department upon request, records including computerized records that may be necessary to comply with the reporting, recordkeeping and emission statement requirements in 25 Pa. Code Chapter 135 (relating to reporting of sources). In accordance with 25 Pa. Code Chapter 135, § 135.5, such records may include records of production, fuel usage, maintenance of production or pollution control equipment or other information determined by the Department to be necessary for identification and quantification of potential and actual air contaminant emissions.

#021 [25 Pa. Code § 127.441(a)]**Property Rights.**

This permit does not convey any property rights of any sort, or any exclusive privileges.

#022 [25 Pa. Code § 127.447]**Alternative Operating Scenarios.**

The permittee is authorized to make changes at the facility to implement alternative operating scenarios identified in this permit in accordance with 25 Pa. Code § 127.447.

**SECTION B. General State Only Requirements****#023 [25 Pa. Code §135.3]****Reporting**

(a) If the facility is a Synthetic Minor Facility, the permittee shall submit by March 1 of each year an annual emissions report for the preceding calendar year. The report shall include information for all active previously reported sources, new sources which were first operated during the preceding calendar year, and sources modified during the same period which were not previously reported. All air emissions from the facility should be estimated and reported.

(b) A source owner or operator of a Synthetic Minor Facility may request an extension of time from the Department for the filing of an annual emissions report, and the Department may grant the extension for reasonable cause.

#024 [25 Pa. Code §135.4]**Report Format**

If applicable, the emissions reports shall contain sufficient information to enable the Department to complete its emission inventory. Emissions reports shall be made by the source owner or operator in a format specified by the Department.

**SECTION C. Site Level Requirements****I. RESTRICTIONS.****Emission Restriction(s).****# 001 [25 Pa. Code §123.1]****Prohibition of certain fugitive emissions**

The permittee shall not allow the emission into the outdoor atmosphere of a fugitive air contaminant from a source other than the following:

- (a) Construction or demolition of buildings or structures.
- (b) Grading, paving, and maintenance of roads and streets.
- (c) Use of roads and streets. Emissions from material in or on trucks, railroad cars, and other vehicular equipment are not considered as emissions from use of roads and streets.
- (d) Clearing of land.
- (e) Stockpiling of materials.
- (f) Open burning operations.
- (g) Sources and classes of sources other than those identified in (a)-(f), above, for which the permittee has obtained a determination from the Department that fugitive emissions from the source, after appropriate control, meet the following requirements:
 - (1) The emissions are of minor significance with respect to causing air pollution; and
 - (2) The emissions are not preventing or interfering with the attainment or maintenance of any ambient air quality standard.

002 [25 Pa. Code §123.2]**Fugitive particulate matter**

The permittee shall not allow the emission of fugitive particulate matter into the outdoor atmosphere from a source specified in Condition #001 of Section C if the emissions are visible at the point the emissions pass outside the permittee's property.

003 [25 Pa. Code §123.31]**Limitations**

The permittee shall not allow the emission into the outdoor atmosphere of any malodorous air contaminants from any source in such a manner that the malodors are detectable outside the permittee's property.

004 [25 Pa. Code §123.41]**Limitations**

(a) The permittee shall not allow the emission into the outdoor atmosphere of visible air contaminants in such a manner that the opacity of the emission is either of the following:

- (1) Equal to or greater than 20% for a period or periods aggregating more than three minutes in any one hour.
- (2) Equal to or greater than 60% at any time.

(b) This permit condition does not apply to the Source ID 201 batch asphalt plant.

005 [25 Pa. Code §123.42]**Exceptions**

The emission limitations of Condition #004 of Section C shall not apply when:

- (a) The presence of uncombined water is the only reason for failure of the emission to meet the limitations.
- (b) The emission results from the operation of equipment used solely to train and test persons in observing the opacity of visible emissions.
- (c) The emission results from sources specified in Condition #001(a)-(g) of Section C.

**SECTION C. Site Level Requirements****# 006 [25 Pa. Code §127.441]****Operating permit terms and conditions.**

The permittee shall limit the facility's annual emissions to less than the following thresholds during any consecutive 12-month period:

- (a) 100 tons per year (TPY) of nitrogen oxides (NO_x)
- (b) 100 TPY of carbon monoxide (CO)
- (c) 50 TPY of volatile organic compounds (VOC)
- (d) 100 TPY of sulfur oxides (SO_x)
- (e) 100 TPY of PM-10 (particulate matter having an effective aerodynamic diameter less than or equal to a nominal 10 micron body)
- (f) 100 TPY of PM-2.5 (particulate matter having an effective aerodynamic diameter less than or equal to a nominal 2.5 micron body)
- (g) 10 TPY of any individual hazardous air pollutant (HAP)
- (h) 25 TPY of aggregate HAPs

007 [25 Pa. Code §129.14]**Open burning operations**

(a) The permittee shall not allow the open burning of material on the permittee's property in a manner such that:

- (1) The emissions are visible, at any time, at the point such emissions pass outside the permittee's property.
- (2) Malodorous air contaminants from the open burning are detectable outside the permittee's property.
- (3) The emissions interfere with the reasonable enjoyment of life or property.
- (4) The emissions cause damage to vegetation or property.
- (5) The emissions are or may be deleterious to human or animal health.

(b) The requirements of (a), above, do not apply when the open burning operations result from:

- (1) A fire set to prevent or abate a fire hazard, when approved by the Department and set by or under the supervision of a public officer.
- (2) A fire set for the purpose of instructing personnel in fire fighting, when approved by the Department.
- (3) A fire set for the prevention and control of disease or pests, when approved by the Department.
- (4) A fire set solely for recreational or ceremonial purposes.
- (5) A fire set solely for cooking food.

(c) This permit condition does not constitute authorization to burn solid waste pursuant to Section 610(3) of the Solid Waste Management Act (SWMA), contained at 35 P.S. Section 6018.610(3), or any other provision of the SWMA.

II. TESTING REQUIREMENTS.**# 008 [25 Pa. Code §127.441]****Operating permit terms and conditions.**

The Department reserves the right to require exhaust stack testing of the sources referenced in this operating permit to measure emissions for purposes including verification of operating permit condition compliance and estimation of annual air emissions.

009 [25 Pa. Code §139.1]**Sampling facilities.**

Upon the request of the Department, the permittee shall provide adequate sampling ports, safe sampling platforms and adequate utilities for the performance by the Department of tests on such source. In the request, the Department will set

**SECTION C. Site Level Requirements**

forth the time period in which the facilities shall be provided as well as the specifications for such facilities.

010 [25 Pa. Code §139.11]**General requirements.**

(a) As specified in 25 Pa. Code Section 139.11(1), performance tests shall be conducted while the source is operating at maximum routine operating conditions or under such other conditions, within the capacity of the equipment, as may be requested by the Department.

(b) As specified in 25 Pa. Code Section 139.11(2), the Department will consider test results for approval where sufficient information is provided to verify the source conditions existing at the time of the test and where adequate data is available to show the manner in which the test was conducted. Information submitted to the Department shall include, at a minimum, all of the following:

- (1) A thorough source description, including a description of any air cleaning devices and the flue.
- (2) Process conditions, for example, the fuel firing rate, asphalt production rate, pressure differential across the fabric collector, and other conditions which may affect emissions from the process.
- (3) The location of the sampling ports.
- (4) Effluent characteristics, including velocity, temperature, moisture content, gas density (percentage CO, CO₂, O₂, and N₂), static and barometric pressures.
- (5) Sample collection techniques employed, including procedures used, equipment descriptions, and data to verify that isokinetic sampling for particulate matter collection occurred and that acceptable test conditions were met.
- (6) Laboratory procedures and results.
- (7) Calculated results.

III. MONITORING REQUIREMENTS.**# 011 [25 Pa. Code §123.43]****Measuring techniques**

Visible emissions may be measured using either of the following:

- (a) A device approved by the Department and maintained to provide accurate opacity measurements (e.g. Continuous Opacity Monitor).
- (b) Observers trained and certified in EPA Reference Method 9 to measure plume opacity with the naked eye; or with the aid of any device(s) approved by the Department.

012 [25 Pa. Code §127.441]**Operating permit terms and conditions.**

The permittee shall conduct a weekly inspection around the plant periphery during daylight hours when the plant is in production to detect visible emissions, fugitive particulate matter emissions, and malodorous air contaminants. Weekly inspections are necessary to determine:

- (a) The presence of visible emissions. Visible emissions may be measured according to the methods specified in Section C, Condition #011. Alternately, plant personnel who observe visible emissions may report the incidence of visible emissions to the Department within two (2) hours of the incident and make arrangements for a certified observer to measure the visible emissions.
- (b) The presence of fugitive particulate matter emissions beyond the plant property boundaries, as stated in Section C, Condition #002.

**SECTION C. Site Level Requirements**

(c) The presence of malodorous air contaminants beyond the plant property boundaries, as stated in Section C, Condition #003.

(d) The presence of earth or other material from paved streets onto which earth or other material has been transported by trucking or earth-moving equipment, erosion by water, or other means, as stated in Section C, Condition #019(d).

013 [25 Pa. Code §127.441]**Operating permit terms and conditions.**

The permittee shall calculate monthly air emissions from Source IDs 101, 104, and 201 using AP-42 emission factors, manufacturer-supplied emission factors, stack test data, or other method(s) approved by the Department in order to demonstrate compliance with Condition #006 of Section C.

IV. RECORDKEEPING REQUIREMENTS.**# 014 [25 Pa. Code §127.441]****Operating permit terms and conditions.**

(a) The permittee shall maintain records of the monthly air emissions referenced in Condition #013 of Section C.

(b) The permittee shall retain these records for a minimum of five (5) years. The records shall be made available to the Department upon its request.

015 [25 Pa. Code §127.441]**Operating permit terms and conditions.**

(a) The permittee shall maintain records of the monthly usage of each fuel consumed at the entire facility.

(b) The permittee shall maintain records of the monthly asphaltic concrete produced at the facility.

(c) The permittee shall maintain records of the monthly stone crushed at the facility.

(d) The permittee shall maintain records of the monthly non-asphaltic concrete produced at the facility.

(e) The permittee shall retain these records for a minimum of five (5) years. The records shall be made available to the Department upon its request.

016 [25 Pa. Code §127.441]**Operating permit terms and conditions.**

(a) The permittee shall maintain records of the weekly inspections referenced in Condition #012 of Section C. The records shall include, at a minimum, the following information:

(1) The name of the company representative monitoring each inspection.

(2) The date and time of each inspection.

(3) The wind direction during each inspection.

(4) A description of the visible emissions, fugitive particulate matter emissions (beyond the plant property boundaries), and malodorous air contaminants (beyond the plant property boundaries) observed, if any, and actions taken to mitigate them. If no visible emissions or fugitive particulate matter emissions or malodors are observed, then document that none were observed.

(5) A description of actions taken, if applicable, to promptly remove earth or other material from paved streets onto which earth or other material has been transported by trucking or earth-moving equipment, erosion by water, or other means. If no actions are taken, then document that none were taken.

(b) The permittee shall retain these records for a minimum of five (5) years. The records shall be made available to the Department upon its request.

**SECTION C. Site Level Requirements****V. REPORTING REQUIREMENTS.****# 017 [25 Pa. Code §127.442]****Reporting requirements.**

Telephone reports pursuant to any conditions in Section B can be made to the Air Quality Program at 717-705-4702 during normal business hours, or to the Department's Emergency Hotline at any time. The Emergency Hotline phone number is changed/updated periodically. The current Emergency Hotline phone number can be found at <https://www.dep.pa.gov/About/Regional/SouthcentralRegion/Pages/default.aspx>.

018 [25 Pa. Code §135.3]**Reporting**

(a) An annual air emissions report for a given calendar year is due no later than March 1 of the following year and shall be submitted to the Air Quality District Supervisor at the following address, unless otherwise specified:

PA DEP
Southcentral Regional Office
Air Quality Program
909 Elmerton Avenue
Harrisburg, PA 17110-8200

(b) The following information shall be included in the report:

- (1) Monthly and annual air emissions (e.g. CO, NOx, SOx, VOC, PM-10, HAPs) from Source ID 101, 104, and 201
- (2) Air emission calculations (including emission factors used) as referenced in Conditions #013 and #014 of Section C
- (3) Monthly and annual fuel usage
- (4) Monthly and annual asphaltic concrete production
- (5) Monthly and annual stone crushed
- (6) Monthly and annual non-asphaltic concrete production
- (7) Annual days and hours of operation of Source IDs 101, 104, and 201

(c) The permittee may request an extension of time from the Department for the filing of the air emissions report specified in part (a), above, and the Department may grant the extension for reasonable cause.

VI. WORK PRACTICE REQUIREMENTS.**# 019 [25 Pa. Code §123.1]****Prohibition of certain fugitive emissions**

The permittee shall take all reasonable actions to prevent particulate matter from becoming airborne from any source specified in Condition #001(a)-(g) of Section C. These actions shall include, but not be limited to, the following:

- (a) Use, where possible, of water or chemicals for control of dust in the demolition of buildings or structures, construction operations, the grading of roads, or the clearing of land.
- (b) Application of asphalt, oil, water, or suitable chemicals on dirt roads, material stockpiles and other surfaces which may give rise to airborne dusts.
- (c) Paving and maintenance of roadways.
- (d) Prompt removal of earth or other material from paved streets onto which earth or other material has been transported by trucking or earth moving equipment, erosion by water, or other means.

VII. ADDITIONAL REQUIREMENTS.

No additional requirements exist except as provided in other sections of this permit including Section B (State Only General Requirements).

VIII. COMPLIANCE CERTIFICATION.

No additional compliance certifications exist except as provided in other sections of this permit including Section B (relating to State Only General Requirements).



SECTION C. Site Level Requirements

IX. COMPLIANCE SCHEDULE.

No compliance milestones exist.

**SECTION D. Source Level Requirements**

Source ID: 101

Source Name: LIMESTONE CRUSHING PLANT

Source Capacity/Throughput: 500.000 Tons/HR LIMESTONE

Conditions for this source occur in the following groups: G001

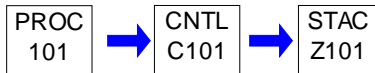
**I. RESTRICTIONS.**

No additional requirements exist except as provided in other sections of this permit including Section B (State Only General Requirements) and/or Section E (Source Group Restrictions).

II. TESTING REQUIREMENTS.

No additional testing requirements exist except as provided in other sections of this permit including Section B (State Only General Requirements) and/or Section E (Source Group Restrictions).

III. MONITORING REQUIREMENTS.

No additional monitoring requirements exist except as provided in other sections of this permit including Section B (State Only General Requirements) and/or Section E (Source Group Restrictions).

IV. RECORDKEEPING REQUIREMENTS.

No additional record keeping requirements exist except as provided in other sections of this permit including Section B (State Only General Requirements) and/or Section E (Source Group Restrictions).

V. REPORTING REQUIREMENTS.

No additional reporting requirements exist except as provided in other sections of this permit including Section B (State Only General Requirements) and/or Section E (Source Group Restrictions).

VI. WORK PRACTICE REQUIREMENTS.**# 001 [25 Pa. Code §127.441]****Operating permit terms and conditions.**

The permittee shall operate Source ID 101's wet suppression system at all times that Source ID 101 is operating. Operation of Source ID 101 without the simultaneous operation of the wet suppression system may occur only in those unusual instances where processed materials contain sufficient moisture so as not to create air contaminant emissions in excess of the limitations and standards of this operating permit. If, however, the wet suppression system is incapable of operation due to weather conditions or any other reason, the permittee may not operate Source ID 101.

002 [25 Pa. Code §127.441]**Operating permit terms and conditions.**

The permittee shall operate and maintain Source ID 101's wet suppression system in accordance with the manufacturer's specifications.

VII. ADDITIONAL REQUIREMENTS.

No additional requirements exist except as provided in other sections of this permit including Section B (State Only General Requirements) and/or Section E (Source Group Restrictions).

**SECTION D. Source Level Requirements**

Source ID: 104

Source Name: BATCH CONCRETE PLANT

Source Capacity/Throughput: 200.000 Cu Yd/HR CONCRETE

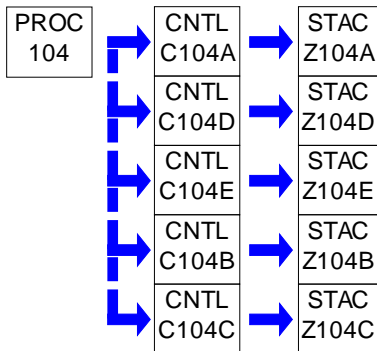
**I. RESTRICTIONS.**

No additional requirements exist except as provided in other sections of this permit including Section B (State Only General Requirements).

II. TESTING REQUIREMENTS.

No additional testing requirements exist except as provided in other sections of this permit including Section B (State Only General Requirements).

III. MONITORING REQUIREMENTS.

No additional monitoring requirements exist except as provided in other sections of this permit including Section B (State Only General Requirements).

IV. RECORDKEEPING REQUIREMENTS.**# 001 [25 Pa. Code §127.441]****Operating permit terms and conditions.**

(a) The permittee shall maintain detailed records of all maintenance performed on Source ID 104's bin vent collectors.

(b) The permittee shall retain these records for a minimum of five (5) years and shall make them available to the Department upon its request.

V. REPORTING REQUIREMENTS.

No additional reporting requirements exist except as provided in other sections of this permit including Section B (State Only General Requirements).

VI. WORK PRACTICE REQUIREMENTS.**# 002 [25 Pa. Code §127.441]****Operating permit terms and conditions.**

The permittee shall operate each Source ID 104 bin vent collector, when applicable, at all times that Source ID 104 is operating.

003 [25 Pa. Code §127.441]**Operating permit terms and conditions.**

The permittee shall operate and maintain Source ID 104's bin vent collectors in accordance with the manufacturer's

**SECTION D. Source Level Requirements**

specifications.

VII. ADDITIONAL REQUIREMENTS.

No additional requirements exist except as provided in other sections of this permit including Section B (State Only General Requirements).

**SECTION D. Source Level Requirements**

Source ID: 201

Source Name: BATCH ASPHALT PLANT

Source Capacity/Throughput: 95.000 MMBTU/HR
 405.000 Tons/HR ASPHALT
 95.000 MCF/HR Natural Gas

Conditions for this source occur in the following groups: G002

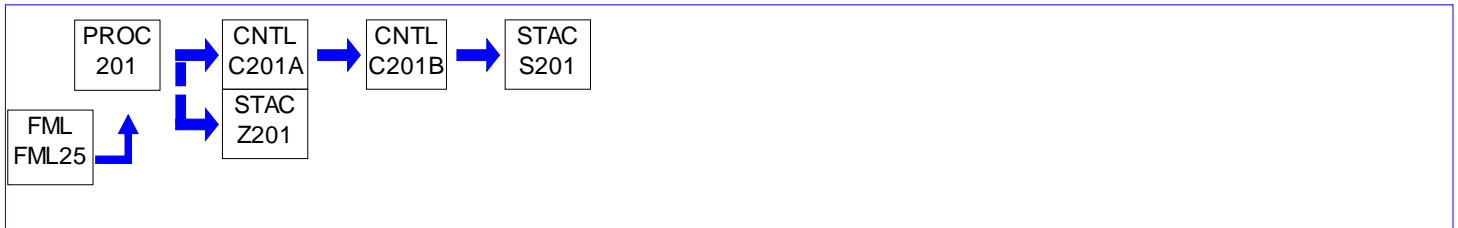
**I. RESTRICTIONS.****Emission Restriction(s).**

001 [25 Pa. Code §123.21]

General

The concentration of sulfur oxides (SO_x), expressed as sulfur dioxide (SO₂), in the fabric collector's (Source ID C201B) effluent gas shall not exceed 500 parts per million, by volume (dry basis).

Fuel Restriction(s).

002 [25 Pa. Code §127.441]

Operating permit terms and conditions.

The permittee shall operate Source ID 201 using natural gas fuel only.

Throughput Restriction(s).

003 [25 Pa. Code §127.441]

Operating permit terms and conditions.

The permittee shall limit operation of Source ID 201, so that no more than a total of 490,000 tons of asphaltic concrete are produced per 12-month rolling total. Records shall be maintained as required by Section C, Condition 015 and reported as required by Section C, Condition 018.

II. TESTING REQUIREMENTS.

No additional testing requirements exist except as provided in other sections of this permit including Section B (State Only General Requirements) and/or Section E (Source Group Restrictions).

III. MONITORING REQUIREMENTS.

004 [25 Pa. Code §127.441]

Operating permit terms and conditions.

The permittee shall maintain instrumentation to measure and display the pressure differential across the fabric collector (Source ID C201B).

IV. RECORDKEEPING REQUIREMENTS.

005 [25 Pa. Code §127.441]

Operating permit terms and conditions.

(a) The permittee shall monitor and record the pressure differential across the fabric collector (Source ID C201B). The pressure differential shall be recorded a minimum of once per week while Source ID 201 is operating.

(b) The permittee shall retain these records for a minimum of five (5) years and shall make them available to the

**SECTION D. Source Level Requirements**

Department upon its request.

006 [25 Pa. Code §127.441]**Operating permit terms and conditions.**

(a) The permittee shall maintain detailed records of all maintenance performed on the knockout box (Source ID C201A) and fabric collector (Source ID C201B).

(b) The permittee shall retain these records for a minimum of five (5) years and shall make them available to the Department upon its request.

V. REPORTING REQUIREMENTS.

No additional reporting requirements exist except as provided in other sections of this permit including Section B (State Only General Requirements) and/or Section E (Source Group Restrictions).

VI. WORK PRACTICE REQUIREMENTS.**# 007 [25 Pa. Code §127.441]****Operating permit terms and conditions.**

The permittee shall operate and maintain the knockout box (Source ID C201A) and fabric collector (Source ID C201B) in accordance with the manufacturer's specifications.

008 [25 Pa. Code §127.441]**Operating permit terms and conditions.**

The permittee shall operate the knockout box (Source ID C201A) and fabric collector (Source ID C201B) at all times that Source ID 201 is operating.

VII. ADDITIONAL REQUIREMENTS.

No additional requirements exist except as provided in other sections of this permit including Section B (State Only General Requirements) and/or Section E (Source Group Restrictions).

**SECTION E. Source Group Restrictions.**

Group Name: G001

Group Description: 40 CFR Part 60 Subpart 000

Sources included in this group

ID	Name
101	LIMESTONE CRUSHING PLANT

I. RESTRICTIONS.

No additional requirements exist except as provided in other sections of this permit including Section B (State Only General Requirements).

II. TESTING REQUIREMENTS.

No additional testing requirements exist except as provided in other sections of this permit including Section B (State Only General Requirements).

III. MONITORING REQUIREMENTS.

No additional monitoring requirements exist except as provided in other sections of this permit including Section B (State Only General Requirements).

IV. RECORDKEEPING REQUIREMENTS.

No additional record keeping requirements exist except as provided in other sections of this permit including Section B (State Only General Requirements).

V. REPORTING REQUIREMENTS.

No additional reporting requirements exist except as provided in other sections of this permit including Section B (State Only General Requirements).

VI. WORK PRACTICE REQUIREMENTS.

No additional work practice requirements exist except as provided in other sections of this permit including Section B (State Only General Requirements).

VII. ADDITIONAL REQUIREMENTS.**# 001 [40 CFR Part 60 Standards of Performance for New Stationary Sources §40 CFR 60.670]****Subpart 000 - Standards of Performance for Nonmetallic Mineral Processing Plants****Applicability and designation of affected facility.**

§ 60.670 Applicability and designation of affected facility.

(a)(1) Except as provided in paragraphs (a)(2), (b), (c), and (d) of this section, the provisions of this subpart are applicable to the following affected facilities in fixed or portable nonmetallic mineral processing plants: each crusher, grinding mill, screening operation, bucket elevator, belt conveyor, bagging operation, storage bin, enclosed truck or railcar loading station. Also, crushers and grinding mills at hot mix asphalt facilities that reduce the size of nonmetallic minerals embedded in recycled asphalt pavement and subsequent affected facilities up to, but not including, the first storage silo or bin are subject to the provisions of this subpart.

(2) The provisions of this subpart do not apply to the following operations: All facilities located in underground mines; plants without crushers or grinding mills above ground; and wet material processing operations (as defined in § 60.671).

(b) [NA - SOURCES AT THIS SITE ARE SUBJECT TO 000]

(c) [NA - AFFECTED SOURCES DO NOT FALL UNDER LISTED EXEMPTIONS]

(d)(1) When an existing facility is replaced by a piece of equipment of equal or smaller size, as defined in § 60.671, having the same function as the existing facility, and there is no increase in the amount of emissions, the new facility is exempt

**SECTION E. Source Group Restrictions.**

from the provisions of §§ 60.672, 60.674, and 60.675 except as provided for in paragraph (d)(3) of this section.

(2) An owner or operator complying with paragraph (d)(1) of this section shall submit the information required in § 60.676(a).

(3) An owner or operator replacing all existing facilities in a production line with new facilities does not qualify for the exemption described in paragraph (d)(1) of this section and must comply with the provisions of §§ 60.672, 60.674 and 60.675.

(e) An affected facility under paragraph (a) of this section that commences construction, modification, or reconstruction after August 31, 1983, is subject to the requirements of this part.

(f) Table 1 of this subpart specifies the provisions of subpart A of this part 60 that do not apply to owners and operators of affected facilities subject to this subpart or that apply with certain exceptions.

§ 60.672 Standard for particulate matter (PM).

(a) [NA - NO CAPTURE SYSTEMS USED]

(b) Affected facilities must meet the fugitive emission limits and compliance requirements in Table 3 of this subpart within 60 days after achieving the maximum production rate at which the affected facility will be operated, but not later than 180 days after initial startup as required under § 60.11. The requirements in Table 3 of this subpart apply for fugitive emissions from affected facilities without capture systems and for fugitive emissions escaping capture systems.

TABLE 3 REQUIREMENTS:

For affected facilities (as defined in §§ 60.670 and 60.671) that commenced construction, modification, or reconstruction after August 31, 1983 but before April 22, 2008, the owner or operator must meet the following fugitive emissions limit for grinding mills, screening operations, bucket elevators, transfer points on belt conveyors, bagging operations, storage bins, enclosed truck or railcar loading stations or from any other affected facility (as defined in §§ 60.670 and 60.671): 10 percent opacity. The owner or operator must meet the following fugitive emissions limit for crushers at which a capture system is not used: 15 percent opacity. The owner or operator must demonstrate compliance with these limits by conducting an initial performance test according to § 60.11 of this part and § 60.675 of this subpart.

[THIS SUBPARAGRAPH ONLY APPLIES TO THE 2012 SECONDARY CRUSHER] For affected facilities (as defined in §§ 60.670 and 60.671) that commence construction, modification, or reconstruction on or after April 22, 2008, the owner or operator must meet the following fugitive emissions limit for grinding mills, screening operations, bucket elevators, transfer points on belt conveyors, bagging operations, storage bins, enclosed truck or railcar loading stations or from any other affected facility (as defined in §§ 60.670 and 60.671): 7 percent opacity. The owner or operator must meet the following fugitive emissions limit for crushers at which a capture system is not used: 12 percent opacity. The owner or operator must demonstrate compliance with these limits by conducting a repeat performance test according to § 60.11 of this part and § 60.675 of this subpart within 5 years from the previous performance test for fugitive emissions from affected facilities without water sprays. Affected facilities controlled by water carryover from upstream water sprays that are inspected according to the requirements in § 60.674(b) and § 60.676(b) are exempt from this 5-year repeat testing requirement.

(c) [Reserved]

(d) Truck dumping of nonmetallic minerals into any screening operation, feed hopper, or crusher is exempt from the requirements of this section.

(e) If any transfer point on a conveyor belt or any other affected facility is enclosed in a building, then each enclosed affected facility must comply with the emission limits in paragraphs (a) and (b) of this section, or the building enclosing the affected facility or facilities must comply with the following emission limits:

(1) Fugitive emissions from the building openings (except for vents as defined in § 60.671) must not exceed 7 percent opacity; and

**SECTION E. Source Group Restrictions.**

(2) [NA - BECAUSE TABLE 2 IS NA]

(f) [NA - NO BAGHOUSES]

§ 60.673 Reconstruction.

(a) The cost of replacement of ore-contact surfaces on processing equipment shall not be considered in calculating either the "fixed capital cost of the new components" or the "fixed capital cost that would be required to construct a comparable new facility" under § 60.15. Ore-contact surfaces are crushing surfaces; screen meshes, bars, and plates; conveyor belts; and elevator buckets.

(b) Under § 60.15, the "fixed capital cost of the new components" includes the fixed capital cost of all depreciable components (except components specified in paragraph (a) of this section) which are or will be replaced pursuant to all continuous programs of component replacement commenced within any 2-year period following August 31, 1983.

§ 60.674 Monitoring of operations.

(a) [NA - NO WET SCRUBBERS]

(b) [THIS SUBSECTION ONLY APPLIES TO THE 2012 SECONDARY CRUSHER] The owner or operator of any affected facility for which construction, modification, or reconstruction commenced on or after April 22, 2008, that uses wet suppression to control emissions from the affected facility must perform monthly periodic inspections to check that water is flowing to discharge spray nozzles in the wet suppression system. The owner or operator must initiate corrective action within 24 hours and complete corrective action as expeditiously as practical if the owner or operator finds that water is not flowing properly during an inspection of the water spray nozzles. The owner or operator must record each inspection of the water spray nozzles, including the date of each inspection and any corrective actions taken, in the logbook required under § 60.676(b).

(1) If an affected facility relies on water carryover from upstream water sprays to control fugitive emissions, then that affected facility is exempt from the 5-year repeat testing requirement specified in Table 3 of this subpart provided that the affected facility meets the criteria in paragraphs (b)(1)(i) and (ii) of this section:

(i) The owner or operator of the affected facility conducts periodic inspections of the upstream water spray(s) that are responsible for controlling fugitive emissions from the affected facility. These inspections are conducted according to paragraph (b) of this section and § 60.676(b), and

(ii) The owner or operator of the affected facility designates which upstream water spray(s) will be periodically inspected at the time of the initial performance test required under § 60.11 of this part and § 60.675 of this subpart.

(2) If an affected facility that routinely uses wet suppression water sprays ceases operation of the water sprays or is using a control mechanism to reduce fugitive emissions other than water sprays during the monthly inspection (for example, water from recent rainfall), the logbook entry required under § 60.676(b) must specify the control mechanism being used instead of the water sprays.

(c) [NA - NO BAGHOUSES]

(d) [NA - BAG LEAK DETECTION NOT USED ON THE NEW SOURCES]

(e) [NA - NEW SOURCES NOT SUBJECT TO AAAAA]

§ 60.675 Test methods and procedures.

(a) In conducting the performance tests required in § 60.8, the owner or operator shall use as reference methods and procedures the test methods in appendices A-1 through A-7 of this part or other methods and procedures as specified in this section, except as provided in § 60.8(b). Acceptable alternative methods and procedures are given in paragraph (e) of this section.

**SECTION E. Source Group Restrictions.**

(b) [NA - BECAUSE TABLE 2 DOES NOT APPLY]

(c)(1) In determining compliance with the particulate matter standards in § 60.672(b) or § 60.672(e)(1), the owner or operator shall use Method 9 of Appendix A-4 of this part and the procedures in § 60.11, with the following additions:

- (i) The minimum distance between the observer and the emission source shall be 4.57 meters (15 feet).
- (ii) The observer shall, when possible, select a position that minimizes interference from other fugitive emission sources (e.g., road dust). The required observer position relative to the sun (Method 9 of Appendix A-4 of this part, Section 2.1) must be followed.
- (iii) For affected facilities using wet dust suppression for particulate matter control, a visible mist is sometimes generated by the spray. The water mist must not be confused with particulate matter emissions and is not to be considered a visible emission. When a water mist of this nature is present, the observation of emissions is to be made at a point in the plume where the mist is no longer visible.

(2) [NA - NO BAGHOUSES]

(3) When determining compliance with the fugitive emissions standard for any affected facility described under § 60.672(b) or § 60.672(e)(1) of this subpart, the duration of the Method 9 (40 CFR part 60, Appendix A-4) observations must be 30 minutes (five 6-minute averages). Compliance with the applicable fugitive emission limits in Table 3 of this subpart must be based on the average of the five 6-minute averages.

(d) To demonstrate compliance with the fugitive emission limits for buildings specified in § 60.672(e)(1), the owner or operator must complete the testing specified in paragraph (d)(1) and (2) of this section. Performance tests must be conducted while all affected facilities inside the building are operating.

(1) If the building encloses any affected facility that commences construction, modification, or reconstruction on or after April 22, 2008, the owner or operator of the affected facility must conduct an initial Method 9 (40 CFR part 60, Appendix A-4) performance test according to this section and § 60.11.

(2) If the building encloses only affected facilities that commenced construction, modification, or reconstruction before April 22, 2008, and the owner or operator has previously conducted an initial Method 22 (40 CFR part 60, Appendix A-7) performance test showing zero visible emissions, then the owner or operator has demonstrated compliance with the opacity limit in § 60.672(e)(1). If the owner or operator has not conducted an initial performance test for the building before April 22, 2008, then the owner or operator must conduct an initial Method 9 (40 CFR part 60, Appendix A-4) performance test according to this section and § 60.11 to show compliance with the opacity limit in § 60.672(e)(1).

(e) The owner or operator may use the following as alternatives to the reference methods and procedures specified in this section:

(1) For the method and procedure of paragraph (c) of this section, if emissions from two or more facilities continuously interfere so that the opacity of fugitive emissions from an individual affected facility cannot be read, either of the following procedures may be used:

(i) Use for the combined emission stream the highest fugitive opacity standard applicable to any of the individual affected facilities contributing to the emissions stream.

(ii) Separate the emissions so that the opacity of emissions from each affected facility can be read.

(2) A single visible emission observer may conduct visible emission observations for up to three fugitive, stack, or vent emission points within a 15-second interval if the following conditions are met:

(i) No more than three emission points may be read concurrently.

(ii) All three emission points must be within a 70 degree viewing sector or angle in front of the observer such that the proper sun position can be maintained for all three points.

**SECTION E. Source Group Restrictions.**

(iii) If an opacity reading for any one of the three emission points equals or exceeds the applicable standard, then the observer must stop taking readings for the other two points and continue reading just that single point.

(3) [NA - BECAUSE TABLE 2 DOES NOT APPLY]

(4) [NA - BECAUSE TABLE 2 DOES NOT APPLY]

(f) [NA - NO WET SCRUBBERS]

(g) For performance tests involving only Method 9 (40 CFR part 60 Appendix A-4) testing, the owner or operator may reduce the 30-day advance notification of performance test in § 60.7(a)(6) and 60.8(d) to a 7-day advance notification.

(h) [Reserved]

(i) If the initial performance test date for an affected facility falls during a seasonal shut down (as defined in § 60.671 of this subpart) of the affected facility, then with approval from the permitting authority, the owner or operator may postpone the initial performance test until no later than 60 calendar days after resuming operation of the affected facility.

§ 60.676 Reporting and recordkeeping.

(a) Each owner or operator seeking to comply with § 60.670(d) shall submit to the Administrator the following information about the existing facility being replaced and the replacement piece of equipment.

(1) For a crusher, grinding mill, bucket elevator, bagging operation, or enclosed truck or railcar loading station:

(i) The rated capacity in megagrams or tons per hour of the existing facility being replaced and

(ii) The rated capacity in tons per hour of the replacement equipment.

(2) For a screening operation:

(i) The total surface area of the top screen of the existing screening operation being replaced and

(ii) The total surface area of the top screen of the replacement screening operation.

(3) For a conveyor belt:

(i) The width of the existing belt being replaced and

(ii) The width of the replacement conveyor belt.

(4) For a storage bin:

(i) The rated capacity in megagrams or tons of the existing storage bin being replaced and

(ii) The rated capacity in megagrams or tons of replacement storage bins.

(b)(1) Owners or operators of affected facilities (as defined in §§ 60.670 and 60.671) for which construction, modification, or reconstruction commenced on or after April 22, 2008, must record each periodic inspection required under § 60.674(b) or (c), including dates and any corrective actions taken, in a logbook (in written or electronic format). The owner or operator must keep the logbook onsite and make hard or electronic copies (whichever is requested) of the logbook available to the Administrator upon request.

(2) [NA - BAG LEAK DETECTION NOT USED]

(3) [NA - NEW SOURCES NOT SUBJECT TO AAAAA]

**SECTION E. Source Group Restrictions.**

(c) [NA - NO WET SCRUBBERS]

(d) [NA - NO WET SCRUBBERS]

(e) [NA - BECAUSE (d) DOES NOT APPLY]

(f) The owner or operator of any affected facility shall submit written reports of the results of all performance tests conducted to demonstrate compliance with the standards set forth in § 60.672 of this subpart, including reports of opacity observations made using Method 9 (40 CFR part 60, Appendix A-4) to demonstrate compliance with § 60.672(b), (e) and (f).

(g) The owner or operator of any wet material processing operation that processes saturated and subsequently processes unsaturated materials, shall submit a report of this change within 30 days following such change. At the time of such change, this screening operation, bucket elevator, or belt conveyor becomes subject to the applicable opacity limit in § 60.672(b) and the emission test requirements of § 60.11.

(h) The subpart A requirement under § 60.7(a)(1) for notification of the date construction or reconstruction commenced is waived for affected facilities under this subpart.

(i) A notification of the actual date of initial startup of each affected facility shall be submitted to the Administrator.

(1) For a combination of affected facilities in a production line that begin actual initial startup on the same day, a single notification of startup may be submitted by the owner or operator to the Administrator. The notification shall be postmarked within 15 days after such date and shall include a description of each affected facility, equipment manufacturer, and serial number of the equipment, if available.

(2) For portable aggregate processing plants, the notification of the actual date of initial startup shall include both the home office and the current address or location of the portable plant.

(j) The requirements of this section remain in force until and unless the Agency, in delegating enforcement authority to a State under section 111(c) of the Act, approves reporting requirements or an alternative means of compliance surveillance adopted by such States. In that event, affected facilities within the State will be relieved of the obligation to comply with the reporting requirements of this section, provided that they comply with requirements established by the State.

(k) Notifications and reports required under this subpart and under subpart A of this part to demonstrate compliance with this subpart need only to be sent to the EPA Region or the State which has been delegated authority according to § 60.4(b).

Regulatory Changes

Individual sources within this source group that are subject to 40 CFR Part 60 Subpart OOO shall comply with all applicable requirements of the Subpart. 40 CFR 60.4 requires submission of copies of all requests, reports and other communications to both the Department and the EPA. The EPA copies shall be forwarded to:

Director
Air Protection Division (3AP00)
U.S. EPA Region III
1650 Arch Street
Philadelphia, PA 19103-2029

The Department copies shall be forwarded to:

Regional Air Program Manager
PA Department of Environmental Protection
909 Elmerton Avenue
Harrisburg, PA 17110-8200

In the event that the Federal Subpart that is the subject of this Source Group is revised, the permittee shall comply with the revised version of the subpart, and shall not be required to comply with any provisions in this permit designated as having

**SECTION E. Source Group Restrictions.**

the subpart as their authority, to the extent that such permit provisions would be inconsistent with the applicable provisions of the revised subpart.

**SECTION E. Source Group Restrictions.**

Group Name: G002

Group Description: 40 CFR Part 60 Subpart I

Sources included in this group

ID	Name
201	BATCH ASPHALT PLANT

I. RESTRICTIONS.**Emission Restriction(s).****# 001 [40 CFR Part 60 Standards of Performance for New Stationary Sources §40 CFR 60.92]****Subpart I - Standards of Performance for Hot Mix Asphalt Facilities****Standard for particulate matter.**

(a) On and after the date on which the performance test required to be conducted by §60.8 is completed, no owner or operator subject to the provisions of this subpart shall discharge or cause the discharge into the atmosphere from any affected facility any gases which:

- (1) Contain particulate matter in excess of 90 mg/dscm (0.04 gr/dscf).
- (2) Exhibit 20 percent opacity, or greater.

[39 FR 9314, Mar. 8, 1974, as amended at 40 FR 46259, Oct. 6, 1975]

II. TESTING REQUIREMENTS.**# 002 [40 CFR Part 60 Standards of Performance for New Stationary Sources §40 CFR 60.93]****Subpart I - Standards of Performance for Hot Mix Asphalt Facilities****Test methods and procedures.**

(a) In conducting the performance tests required in §60.8, the owner or operator shall use as reference methods and procedures the test methods in appendix A of this part or other methods and procedures as specified in this section, except as provided in §60.8(b).

(b) The owner or operator shall determine compliance with the particulate matter standards in §60.92 as follows:

(1) Method 5 shall be used to determine the particulate matter concentration. The sampling time and sample volume for each run shall be at least 60 minutes and 0.90 dscm (31.8 dscf).

(2) Method 9 and the procedures in §60.11 shall be used to determine opacity.

[54 FR 6667, Feb. 14, 1989]

III. MONITORING REQUIREMENTS.

No additional monitoring requirements exist except as provided in other sections of this permit including Section B (State Only General Requirements).

IV. RECORDKEEPING REQUIREMENTS.

No additional record keeping requirements exist except as provided in other sections of this permit including Section B (State Only General Requirements).

V. REPORTING REQUIREMENTS.**# 003 [40 CFR Part 60 Standards of Performance for New Stationary Sources §40 CFR 60.4]****Subpart A - General Provisions****Address.**

Source ID 201 is subject to 40 CFR Part 60, Subpart I - Standards of Performance for Hot Mix Asphalt Facilities. The permittee shall comply with 40 CFR Section 60.4, which requires submission of copies of all requests, reports,

**SECTION E. Source Group Restrictions.**

applications, submittals, and other communications to both the U.S. EPA and the Department. The U.S. EPA copies shall be forwarded to:

Director
Air Protection Division
U.S. EPA, Region III
1650 Arch Street
Philadelphia, PA 19103-2029

The Department copies shall be forwarded to:

Regional Air Program Manager
PA Department of Environmental Protection
909 Elmerton Avenue
Harrisburg, PA 17110-8200

In the event that the Federal Subpart that is the subject of this Source Group is revised, the permittee shall comply with the revised version of the subpart, and shall not be required to comply with any provisions in this permit designated as having the subpart as their authority, to the extent that such permit provisions would be inconsistent with the applicable provisions of the revised subpart.

VI. WORK PRACTICE REQUIREMENTS.

No additional work practice requirements exist except as provided in other sections of this permit including Section B (State Only General Requirements).

VII. ADDITIONAL REQUIREMENTS.**# 004 [40 CFR Part 60 Standards of Performance for New Stationary Sources §40 CFR 60.90]****Subpart I - Standards of Performance for Hot Mix Asphalt Facilities****Applicability and designation of affected facility.**

(a) The affected facility to which the provisions of this subpart apply is each hot mix asphalt facility. For the purpose of this subpart, a hot mix asphalt facility is comprised only of any combination of the following: dryers; systems for screening, handling, storing, and weighing hot aggregate; systems for loading, transferring, and storing mineral filler, systems for mixing hot mix asphalt; and the loading, transfer, and storage systems associated with emission control systems.

(b) Any facility under paragraph (a) of this section that commences construction or modification after June 11, 1973, is subject to the requirements of this subpart.

[42 FR 37936, July 25, 1977, as amended at 51 FR 12325, Apr. 10, 1986]



SECTION F. Alternative Operation Requirements.

No Alternative Operations exist for this State Only facility.



SECTION G. Emission Restriction Summary.

No emission restrictions listed in this section of the permit.



SECTION H. Miscellaneous.

Source 101 (Limestone Crushing Plant) consists of the following equipment:

Equipment subject to 40 CFR Part 60, Subpart OOO, constructed after April 22, 2008:

- 51" X 24' Lippmann Feeder
- Primary Crusher, 42" X 48" Lippman Jaw with Breaker (TOKU)
- Primary Screen, 6' X 16' triple deck screener (Diester, BXHM-3616)
- Syntron 1 (Syntron, F450, feeder)
- Syntron 2 (Syntron, F450, feeder)
- Cone Syntron (Syntron, F450, feeder)
- Secondary Crusher (Metso, GP300S)
- Secondary Screen conn-weld 8x20
- Tertiary Crusher (Superior Industries Patriot P400, 400 tph)
- JVI Pan Feeder and Surge bin (tertiary crusher feeder)
- PC1, under jaw to primary screen belt (42" X 40')
- PC2, jaw to primary screen belt (42" X 265')
- PC3, 2A Flat, under primary screen to 2A belt (30" X 30')
- PC4, 2A Stacker, primary to 2A Stockpile belt (30" X 120')
- PC5, 4' Stacker, belt (30" X 80')
- PC6, 4's Flat, primary to 2A Stockpile belt (30" X 30')
- PC7, Surge Belt, primary to surge pile (42" X 250')
- Vibrating Feeders to tunnel belt
- TC1, Tunnel Belt, Under Surge to Cone (42" X 233')
- C1, secondary crusher to cone belt
- C2, Cone Belt, under Cone to #2 belt (42" X 159')

Equipment subject to 40 CFR Part 60, Subpart OOO, constructed after August 31, 1983 and before April 22, 2008:

- Tertiary Screen, 5' X 16' Screen (Deister BFO-3516)
- Series of 15 belts (C4, C5, C6, C7, C8, C9, C10, C11, C12, C13, C14, C15, C17, C18, and C20)

Additionally, the limestone crushing plant includes a wash plant not subject to 40 CFR Part 60, Subpart OOO which includes the following equipment handling saturated materials:

- Wash Plant Screen (Deister, HM-4620, 6x20) (400 tph capacity)
- Sand Screw (Eagle Iron Works, BMD 15764)
- Series of belts (C22, C23, C24, C25, C26, C27, C28, and C29)

Source 104 (Concrete Plant) consists of the following equipment:

---Equipment-----	Manufacturer*
Cement Silo (125 ton capacity)	Erie Strayer
Cement Silo (35 ton capacity)	Erie Strayer
Cement Silo (35 ton capacity)	Erie Strayer
Fly Ash Silo (50 ton capacity)	Erie Strayer

The cement silos are controlled by a single dedicated Erie Strayer* bin vent collector. The fly ash silo is controlled by a dedicated Erie Strayer* bin vent collector. The cement/fly ash weigh hopper exit is controlled by a dedicated Erie Strayer* bin vent collector. These bin vent collectors have no testable stack.

* or equivalent

Source 201 Batch Asphalt Plant includes the fugitive emissions from the following equipment:

- Asphalt Load Out
- Asphalt Storage Silo
- Hot Oil system

**SECTION H. Miscellaneous.**

The following activities have been exempted from work practice standards, and testing, monitoring, record keeping, and reporting requirements:

- Two (2) 20,000 and (2) 30,000 Gallon Liquid Asphalt Cement Storage Tanks
- Wash Plant
- Sand Classifier
- Hot Oil System, 2.0 mmBtu/hr natural gas burner
- Aqueous Cold Cleaning Station

* Recycled Asphalt Pavement (RAP) Processing Equipment (includes the following: 4' x 8' single deck screen; 2' x 105' conveyor belt; and 2.5' x 2.25' feed hopper)



***** End of Report *****
